

MAINTENANCE INSTRUCTIONS

****SYSTEM PRESSURE MUST BE RELEASED PRIOR TO PERFORMING MAINTENANCE PROCEDURES****

Oil Coalescing / Activated Carbon Element Replacement

- Every 6 months (Required)

First, unscrew tube from Tsunami filter head and then remove baffle nut from threaded rod. Slide the old element off and reinstall with new element. Replace tube and end cap O-rings.

Make sure there is a proper seal between the element, the adaptor, and the baffle plate. Tighten baffle nut until snug. **DO NOT OVERTIGHTEN NUT!**

Screw Tsunami outer tube onto filter head.



Float Drain Replacement (If Needed)

First, remove the bottom cap from the Tsunami filter. Grasp the bottom stem of the float drain and unscrew from bottom cap.

Replace end cap o-ring. Then install the new float drain into bottom cap. Reinstall bottom cap onto filter.

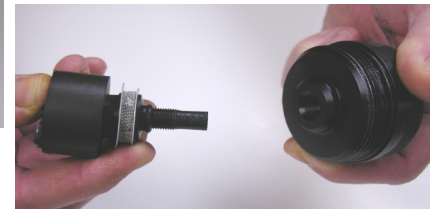

Stainless Steel Element Replacement (If Needed)

Remove outer tube. Remove the nut holding the bottom baffle. Slide center tube and old element away from the Tsunami head and replace with new center tube and element. Install gray baffle and tighten nut until snug. Replace o-rings on tube and end cap. Remove tape and label holding element together, re-install tube.

DO NOT OVERTIGHTEN NUT



Tsunami Compressed Air Solutions™ is a division of Suburban Mfg.



www.gosuburban.com

Phone: 1-800-782-5752 Fax: (763) 295-6601



Water Separator Service Kits

20/50/120/240 CFM

20 Series Water Separator

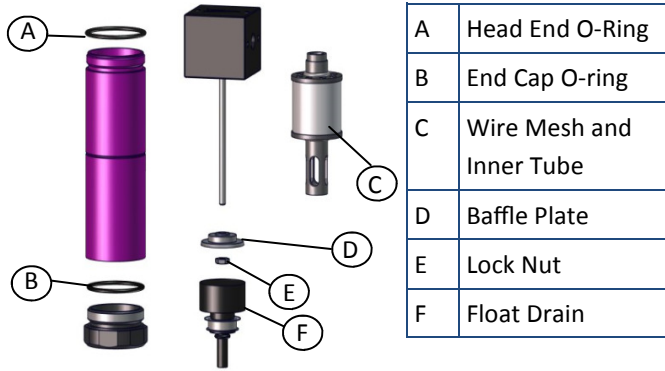

P/N	Description	Includes
21999-0846	Water Separator Service Kit	A, B, C, D, E
21999-0868	Float Drain Pack of 3	F

50 Series Water Separator

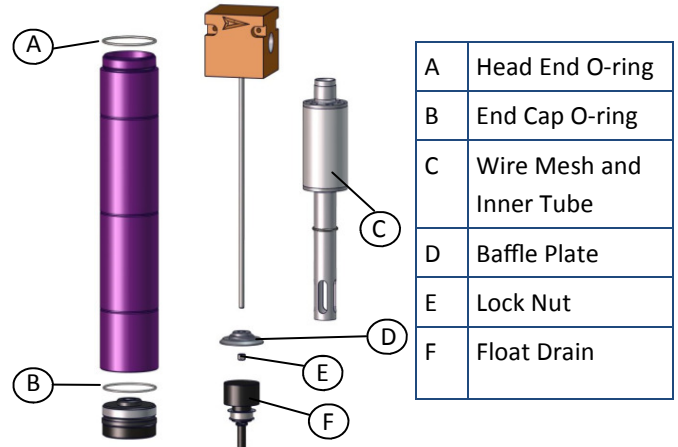

P/N	Description	Includes
21999-0227	Water Separator Service Kit	A, B, C, D, E
21999-0868	Float Drain Pack of 3	F

120/240 Series Water Separator

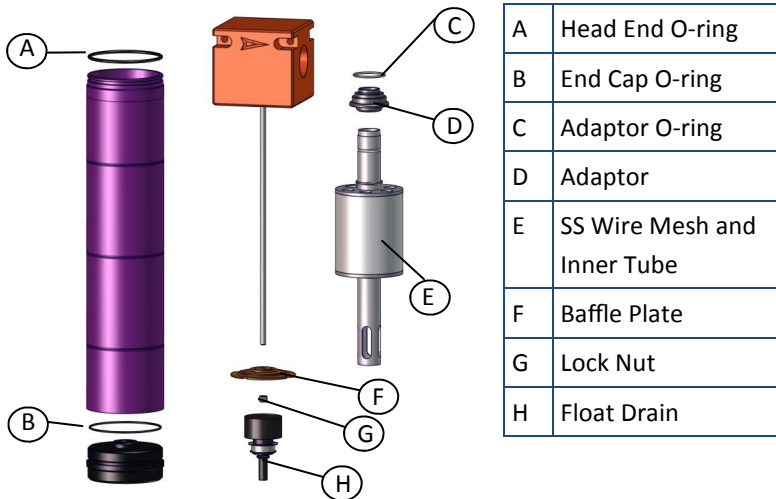

P/N	Description	Includes
21999-0228	Water Separator Service Kit	A, B, C, D, E, F, G
21999-0868	Float Drain Pack of 3	H

240 series systems require 2 service kits

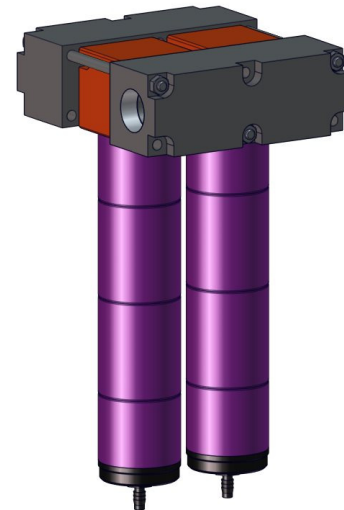

Tsunami Compressed Air Solutions™ is a division of Suburban Mfg.



www.gosuburban.com

Phone:1-800-782-5752 Fax:(763) 295-6601

